



Variant Shape Tool for Finishing

VU-R

PFB-BR • PFB-LZ • VU-TBR • VU-EGG • VU-EGG-H

Volume 1

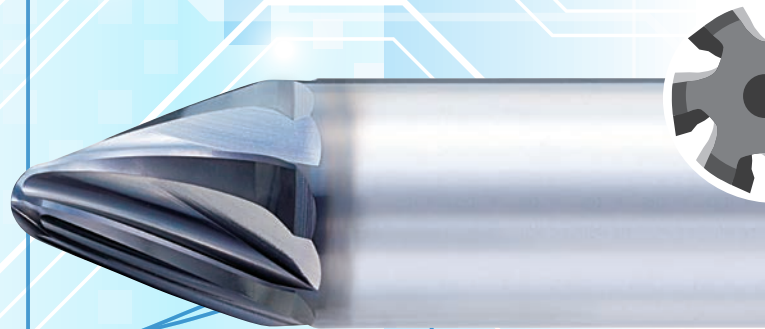
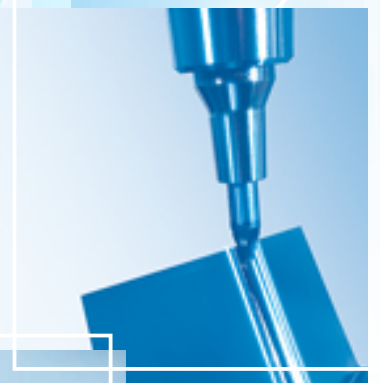
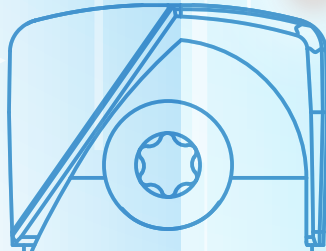
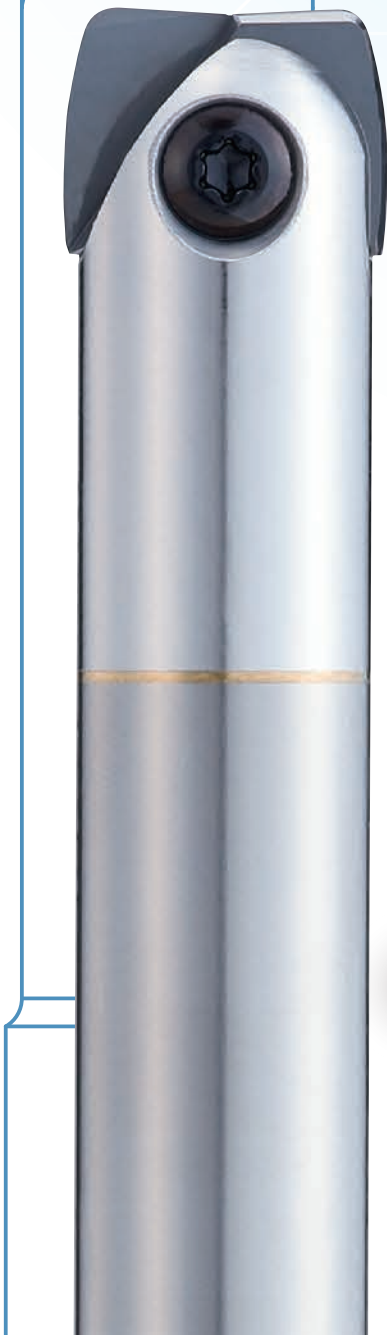
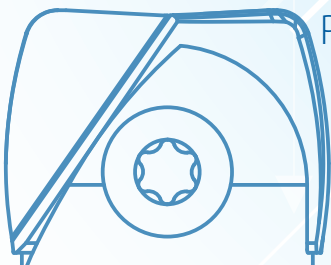

VU-R SERIES VARIANT SHAPE TOOL FOR FINISHING

Improved machining efficiency and surface quality with large radius configuration

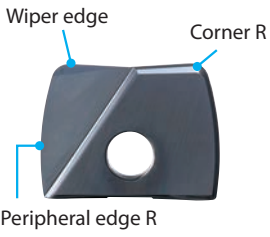
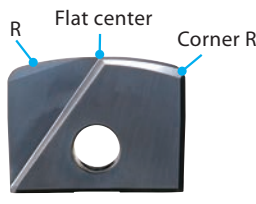
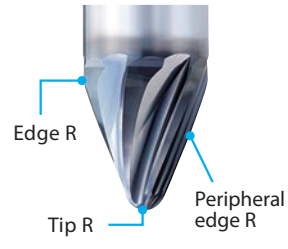
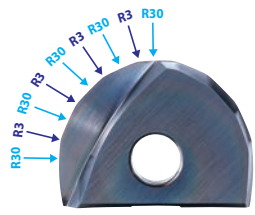
| Indexable Type (PFB) | | Solid Type | Composite Radius Shape Type |
|---|--|---|---|
| Barrel Type Insert PFB-BR <ul style="list-style-type: none"> Contour milling of vertical slope Flat bottom milling  | Lens Type Insert PFB-LZ <ul style="list-style-type: none"> Contour milling of horizontal slope Copy milling of curved surface  | Taper Barrel Type VU-TBR <ul style="list-style-type: none"> Contour milling of vertical slope High-efficiency multi-flute specification  | PolyBall (special tool) <ul style="list-style-type: none"> Improves machined surface quality and reduces processing time for complex shapes with inclined and curved surfaces.  <p>Example of combination of Rs.</p> |

1 Capability to mill with a larger pitch

The barrel type (PFB-BR) can be used with a larger pitch than with the ball type and corner radius type when contour milling with the same theoretical cusp height value.

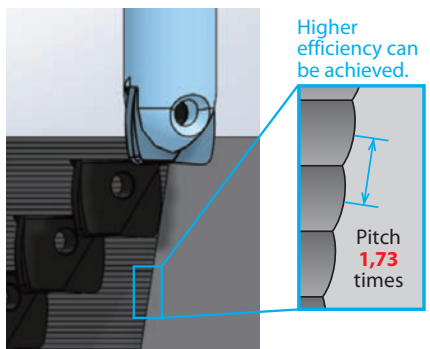
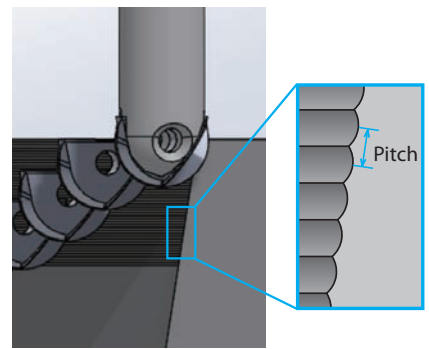
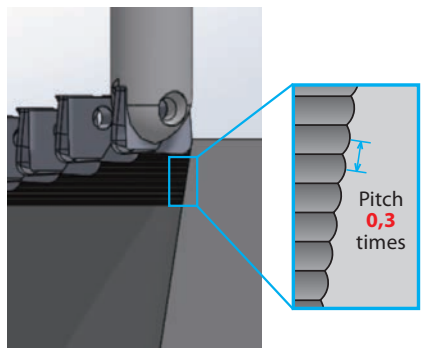
| Barrel Type insert (PFB-BR) | Ball Endmill insert | Corner Radius End Mill Insert |
|--|---|--|
| Example Tool dia.: 20mm Barrel: R30  | Example Tool dia.: 20mm R10  | Example Tool dia.: 20mm Corner R3  |

VU-R SERIES VARIANT SHAPE TOOL FOR FINISHING

2 Large pitch specification greatly improves cutting efficiency

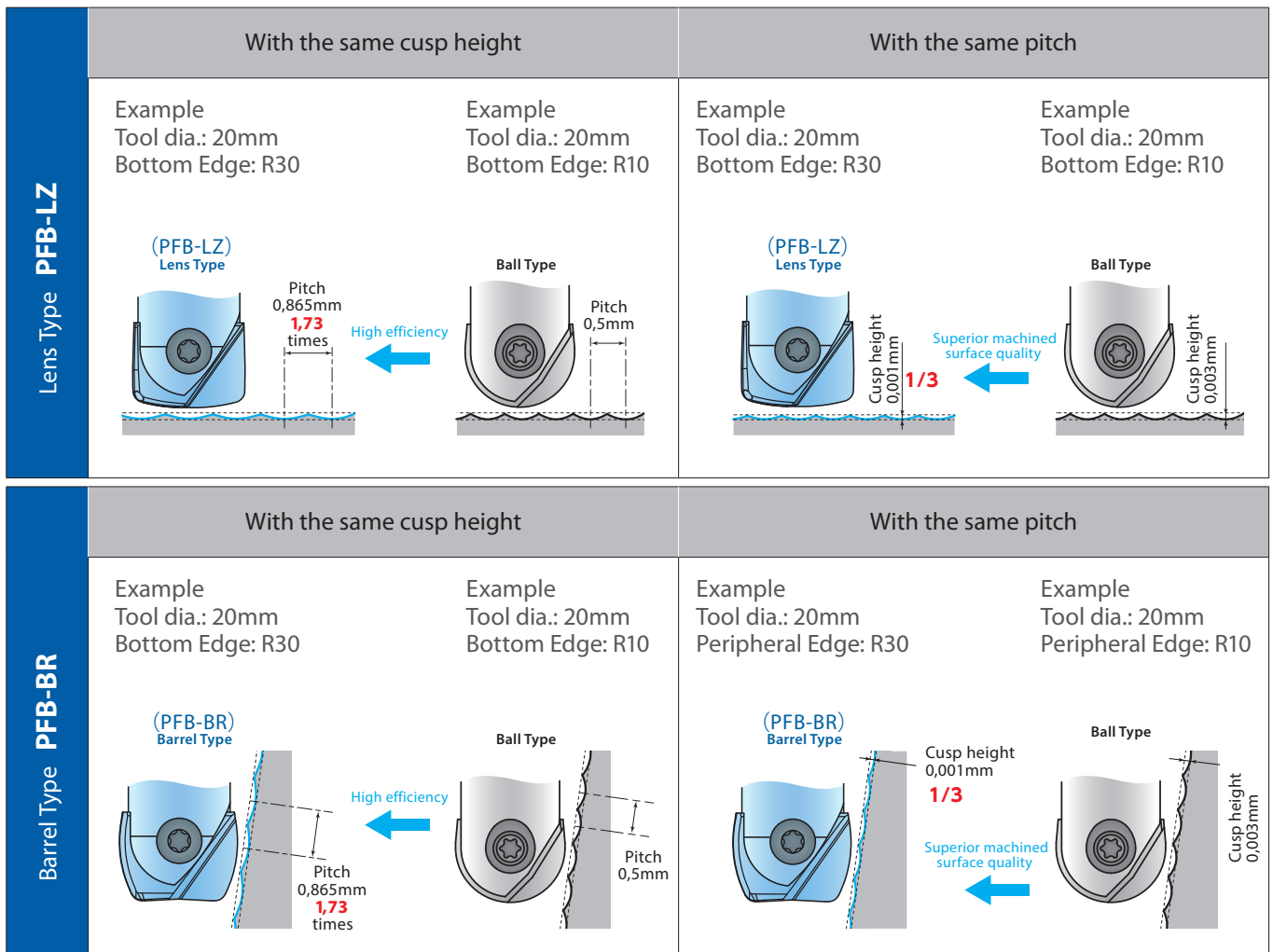

3 Highly efficient finishing with large Peripheral edge R

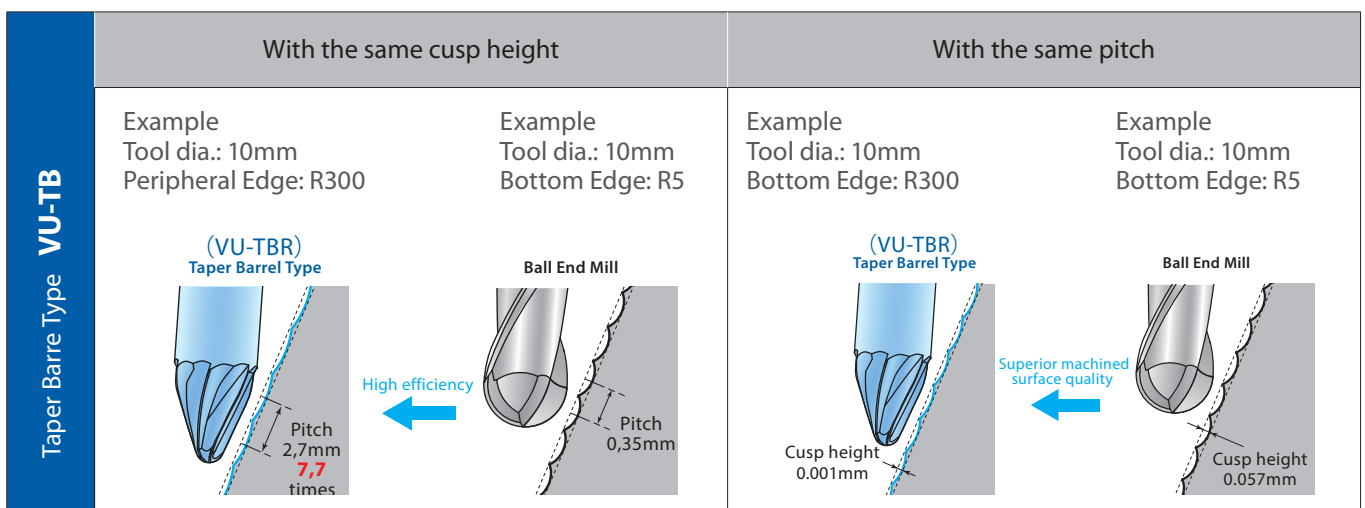

Barrel Type & Lens Type Inserts

Original geometry that enables smooth machined surface and higher cutting efficiency

| Barrel Type Insert PFB-BR | Lens Type PFB-LZ | | | | | | | | | | | | | | | | | | | | | | | | |
|--|--|-------|-----------|-------|-----------|-------|-----------|-------|-------------|-------|-----------|-------|---|-----------|-----|-----------|-------|-----------|-------|-----------|-------|-------------|-------|-----------|-------|
|  <ul style="list-style-type: none"> ● Contour milling of vertical slope ● Flat bottom milling ● Applicable to vertical slopes up to 17,1°(see table below) * For 3-axis machining |  <ul style="list-style-type: none"> ● Contour milling of horizontal slope ● Copy milling of curved surface ● Applicable to horizontal slopes up to 15,7°(see table below) * For 3-axis machining | | | | | | | | | | | | | | | | | | | | | | | | |
|  |  | | | | | | | | | | | | | | | | | | | | | | | | |
|  <p style="text-align: center;">Vertical slope angle</p> <p style="text-align: center;">Applicable maximum vertical slope angle</p> <table border="1"> <tr><td>Ø10 (R15)</td><td>16,6°</td></tr> <tr><td>Ø12 (R18)</td><td>17,1°</td></tr> <tr><td>Ø16 (R24)</td><td>15,8°</td></tr> <tr><td>Ø20 (R30)</td><td>16,6°</td></tr> <tr><td>Ø25 (R37,5)</td><td>16,6°</td></tr> <tr><td>Ø32 (R48)</td><td>16,7°</td></tr> </table> | Ø10 (R15) | 16,6° | Ø12 (R18) | 17,1° | Ø16 (R24) | 15,8° | Ø20 (R30) | 16,6° | Ø25 (R37,5) | 16,6° | Ø32 (R48) | 16,7° |  <p style="text-align: center;">Horizontal slope angle</p> <p style="text-align: center;">Applicable maximum Horizontal slope angle</p> <table border="1"> <tr><td>Ø10 (R15)</td><td>15°</td></tr> <tr><td>Ø12 (R18)</td><td>15,7°</td></tr> <tr><td>Ø16 (R24)</td><td>14,4°</td></tr> <tr><td>Ø20 (R30)</td><td>14,7°</td></tr> <tr><td>Ø25 (R37,5)</td><td>15,1°</td></tr> <tr><td>Ø32 (R48)</td><td>15,4°</td></tr> </table> | Ø10 (R15) | 15° | Ø12 (R18) | 15,7° | Ø16 (R24) | 14,4° | Ø20 (R30) | 14,7° | Ø25 (R37,5) | 15,1° | Ø32 (R48) | 15,4° |
| Ø10 (R15) | 16,6° | | | | | | | | | | | | | | | | | | | | | | | | |
| Ø12 (R18) | 17,1° | | | | | | | | | | | | | | | | | | | | | | | | |
| Ø16 (R24) | 15,8° | | | | | | | | | | | | | | | | | | | | | | | | |
| Ø20 (R30) | 16,6° | | | | | | | | | | | | | | | | | | | | | | | | |
| Ø25 (R37,5) | 16,6° | | | | | | | | | | | | | | | | | | | | | | | | |
| Ø32 (R48) | 16,7° | | | | | | | | | | | | | | | | | | | | | | | | |
| Ø10 (R15) | 15° | | | | | | | | | | | | | | | | | | | | | | | | |
| Ø12 (R18) | 15,7° | | | | | | | | | | | | | | | | | | | | | | | | |
| Ø16 (R24) | 14,4° | | | | | | | | | | | | | | | | | | | | | | | | |
| Ø20 (R30) | 14,7° | | | | | | | | | | | | | | | | | | | | | | | | |
| Ø25 (R37,5) | 15,1° | | | | | | | | | | | | | | | | | | | | | | | | |
| Ø32 (R48) | 15,4° | | | | | | | | | | | | | | | | | | | | | | | | |

Insert grade can be selected according to application

| Grade XP3225 | Grade XP3310 |
|-----------------|-----------------|
|-----------------|-----------------|

- For stable milling of a wide variety of work materials
- Excellent lubricity and wear resistance

- Ideal for dry milling of high hardened steel and cast iron
- Excellent heat and wear resistance

3-axis finishing of mold base vertical slope by barrel type tool (PFB-BR)

| | | |
|--------------------------|---|---|
| Tool | Insert: PFB320R480-BR-ST R48 Shank: PFB-R320SS32-LL300CS | Conventional (Shoulder cutter) Ø40xR3 |
| Work Material | FCD550R | |
| Cutting Speed | 200m/min (1.990min ⁻¹) | 125m/min (995min ⁻¹) |
| Feed Rate | 600mm/min (0,15 mm/t) | 700mm/min |
| Pitch | 0,7mm | 0,35mm |
| Depth of Cut | 0,3mm | |
| Overhang Length | 176mm | |
| Coolant | None (Air Blow) | |
| Machining Time | 2 Hours 12 minutes 8 seconds | 5 Hours 39 minutes 55 seconds |
| Machining surface | Set to almost the same cusp height | |
| Machine | Horizontal Machining Center | |

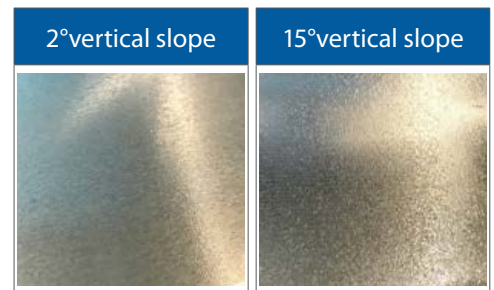
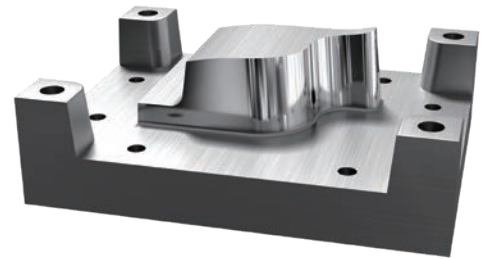

The pitch is set to twice that of conventional tool.
The finished surfaces are extremely satisfactory for both vertical slopes, with the processing efficiency increased by about 30%.

3-axis finishing of die casting mold (engine case) by barrel type tool (PFB-BR)

| | | | |
|--------------------------|---|------------------------------------|--|
| Tool | Insert: PFB320R480-BR-ST R48 Shank: PFB-R320SS32-LL300CS | Conventional (Ball Type) R10 | Competitor (Barrel - Lens Type) R20 |
| Work Material | SKD61 (45HRC) | | |
| Cutting Speed | 150m/min (2.387min ⁻¹) | | |
| Feed Rate | 477mm/min (0,1 mm/t) | | |
| Pitch | 1.01mm | 0,59mm | 0,86mm |
| Depth of Cut | 0.1mm | | |
| Overhang Length | 110mm | | |
| Coolant | Water-Soluble | | |
| Machining Time | 27 minutes 20 seconds | 46 minutes 19 seconds | 31 minutes 53 seconds |
| Cusp height | 0,005mm | | |
| Surface Roughness | Ra=0,49 µm Rz=2,1 µm | Ra=0,88 µm Rz=3,4 µm | Ra=0,65 µm Rz=2,8 µm |
| Machine | Vertical Machining Center | | |

Difference in path based on insert shape

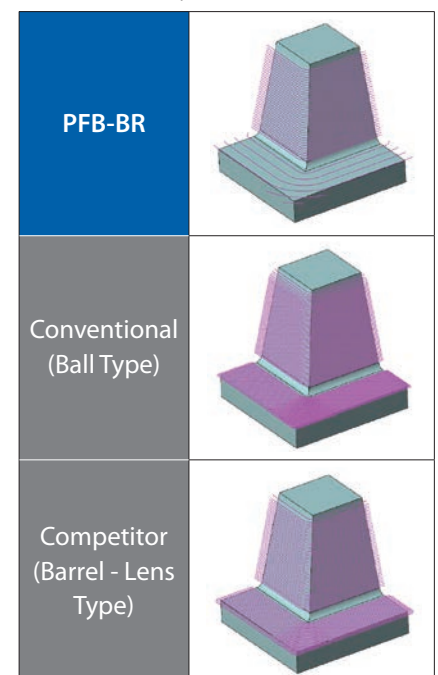

Processing time can be reduced with the larger pitch of the barrel type tool's R30. In addition, the wiper edge of the barrel type tool (PFB-BR) enables higher quality of the bottom surface. Moreover, with the bottom pitch of 0.6 DC (12 mm), processing time can be significantly reduced compared to ball shape and other competitors' barrel and lens type tools.



CUTTING DATA

3-axis finishing of mold base vertical slope by barrel type tool (PFB-BR)

| | | |
|--------------------------|--|---|
| Tool | Insert: PFB200R300-BR-ST R30 Shank: Special Order | Conventional (Shoulder cutter) Ø40xR3 |
| Work Material | FCD550R | |
| Cutting Speed | 182m/min (2.900min ⁻¹) | 113m/min (900min ⁻¹) |
| Feed Rate | 650mm/min (0,11 mm/t) | 500mm/min |
| Pitch | 1mm | 0,35mm |
| Depth of Cut | 0,6mm | |
| Overhang Length | 145mm | |
| Coolant | None (Air Blow) | |
| Machining Time | 9 Hours | 22 Hours |
| Machining surface | Set to almost the same cusp height | |
| Machine | Horizontal Machining Center | |

Machining Time

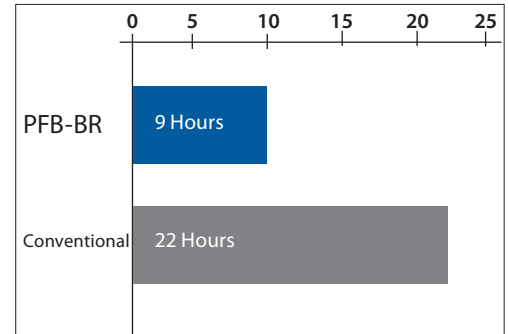

Machined surface

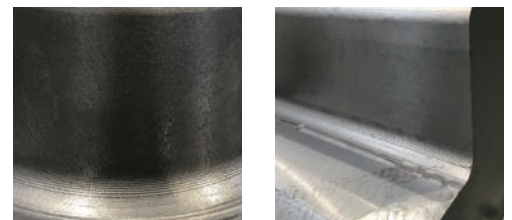

Achieved significant increase in efficiency.

With the conventional tool, the insert has to be replaced after milling one workpiece.

The PFB-BR, however, can complete two or more workpieces before having to be replaced.

3-axis finishing of fixed die vertical slope by barrel type tool (PFB-BR)

| | | |
|------------------------|--|---|
| Tool | Insert: PFB200R300-BR-ST R30 Shank: PFB-R200SS20-L180CS | Conventional (Radius Type) Ø20xR3 |
| Work Material | DH31S Equivalent | |
| Cutting Speed | 220m/min (3.510min ⁻¹) | |
| Feed Rate | 983mm/min (0,14 mm/t) | 1.750mm/min (0,25 mm/t) |
| Pitch | 0,8mm | 0,35mm |
| Depth of Cut | 0,15mm | |
| Overhang Length | 98mm | |
| Coolant | None (Air Blow) | |
| Cutting Method | Contour line finish milling | |
| Machining Time | 28 minutes 40 sec. | 45 minutes 7 sec. |
| Cusp height | 0,002mm | 0,005mm |
| Machine | Horizontal Machining Center | |

Finished surface by PFB-BR

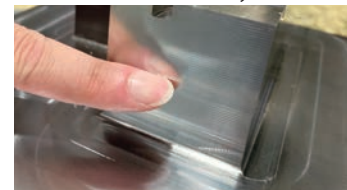

The machined surface quality was so superior that a clear reflection can be seen.

Wear comparison

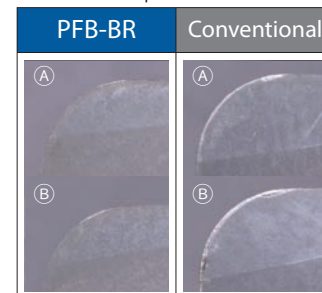

| | Machining Time | | Amount of Wear |
|--------------|------------------------|------------------------------|----------------------------|
| | Time | Wear Status | |
| PFB-BR | 28Minutes 40Seconds | Normal Wear Still Running | Ⓐ : 0,011mm Ⓑ : 0,014mm |
| Conventional | 45Minutes 7Seconds | Chipping | Ⓐ : 0,046mm Ⓑ : 0,088mm |

The conventional radius type insert needs to be replaced before finishing one workpiece due to small pitch. With the barrel type insert (PFB-BR), because the cutting distance became shorter due to the larger pitch, it was possible to complete cutting one workpiece without replacing the tool. The level of precision was also high enough to eliminate polishing.



Finishing of large die by barrel type tool (PFB-BR)

| Tool | Insert: PFB320R480-BR-SH R48 Shank: PFB-R320SS32-LL300CS | Conventional (Ball Type) R6 |
|--------------------|---|------------------------------------|
| Work Material | SC410 | |
| Cutting Speed | 250m/min (2.500min ⁻¹) | 101m/min (2.680min ⁻¹) |
| Feed Rate | 800mm/min (0,16 mm/t) | 1.800mm/min |
| Pitch | 3mm | 2mm |
| Cusp Height | 0,023mm | 0,084mm |
| Overhang Length | 175mm | |
| Coolant | None (Air Blow) | |
| Machining Time | 1,5 Hours x 18 work | 1 Hour x 18 work |
| Numbr of Tools | 3 tools | 6 tools |
| Polishing Time | 4 Hours x 18 work | 6 hours x 18 work |
| Total Machine Time | 99 Hours | 126 Hours |
| Machine | Double Column Machining Center | |

Machining Time

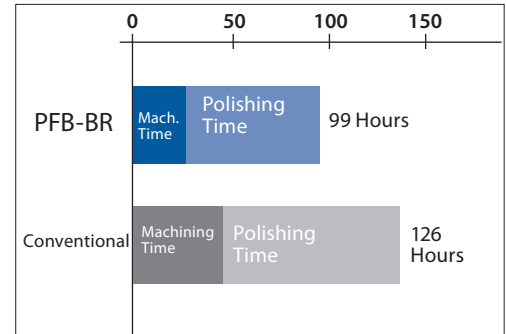

Smooth and considerably high quality surface is achieved due to the effect of the large barrel R. As the surface becomes smoother, polishing time can be significantly reduced and thus the total time required for finishing can also be significantly reduced. By making the pitch larger, the cutting distance is shortened, minimizing the number of tools required for processing.

5-axis finishing of blade with lens type tool (PFB-LZ)

| Tool | Insert: PFB200R300-LZ-ST R30 Shank: PFB-R200SF10 | Competitor Lens Tool R20 |
|------------------|---|--------------------------------|
| Work Material | SUS430 | |
| Cutting Speed | 500m/min (7.961min ⁻¹) | |
| Feed Rate | 2.388mm/min (0,15 mm/t) | 2.388mm/min (0,1mm/t) |
| Pitch | 1,24mm | 1,01mm |
| Depth of Cut | 0,2mm | |
| Overhang Length | 90mm | |
| Coolant | Water-Soluble | |
| Cusp Height | 0,006mm | |
| Machining Time | 196 minutes | 244 minutes |
| Numbr of Process | 12E | |
| Machine | Turbine blade processing machine | |

Machining Time

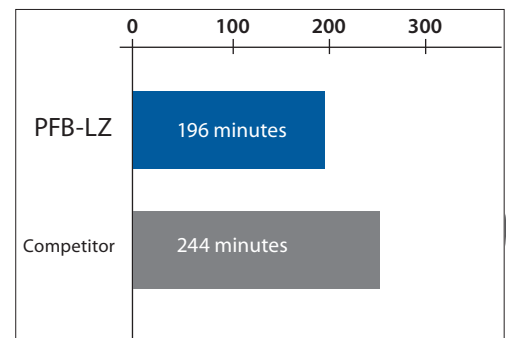

By using PFB-LZ R30 to make the pitch larger, machining time is shortened.



5-axis finishing of turbine blade with lens type tool (PFB-LZ)

| | | | |
|---------------------------|--|--------------------------|------------------------------------|
| Tool | Insert: PFB200R300-LZ-ST R30 Shank: PFB-R200SS20-L180CS | | Conventional (Ball Type) R10 |
| Work Material | SUS430 | | |
| Cutting Speed | 420m/min (6.687min ⁻¹) | | |
| Feed Rate | 5.350mm/min (0,4 mm/t) | | |
| Pitch | 0,866mm | 0,5mm | |
| Depth of Cut | 0,2mm | | |
| Tilt angle of tool | 15° | | |
| Overhang Length | 90mm | | |
| Coolant | Water-Soluble | | |
| Machining Time | 9 minutes 25 seconds | 16 minutes 30 seconds | |
| Cusp Height | 0,003mm | | |
| Machine | Vertical machining center for 5-axis machining (BT50) | | |

Machining Time

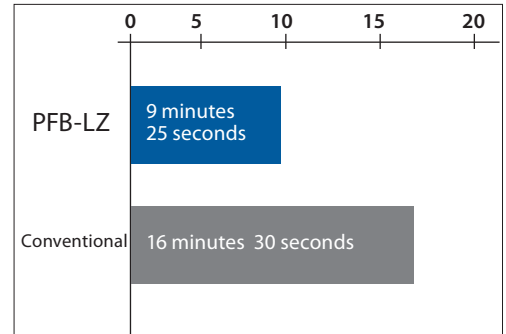

Difference in tool path

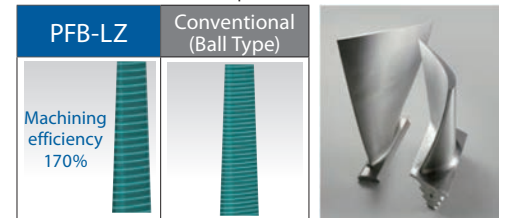

Significant processing time reduction is achieved.

Finishing of large die parts with lens type tool (PFB-LZ) (workpiece mounting process reduction)

| | | |
|------------------------|---|--|
| Tool | Insert: PFB320R480-LZ-SH R48 Shank: PFB-R320SS32-LL300CS | |
| Work Material | PX5 | |
| Cutting Speed | 226m/min (2.250min ⁻¹) | |
| Feed Rate | 650mm/min (0,15 mm/t) | |
| Pitch | 0,8mm | |
| Depth of Cut | 0,2mm | |
| Overhang Length | 176mm | |
| Coolant | None (Air Blow) | |
| Machining Time | 2 Hours 30 minutes | |
| Cusp Height | 0,002mm | |
| Machine | Vertical machining center | |

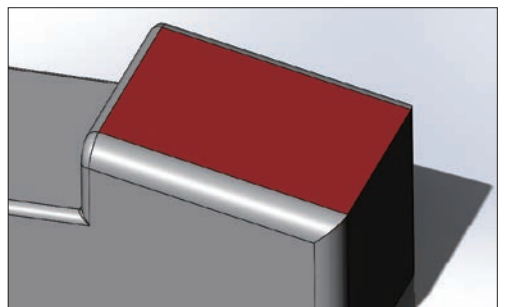
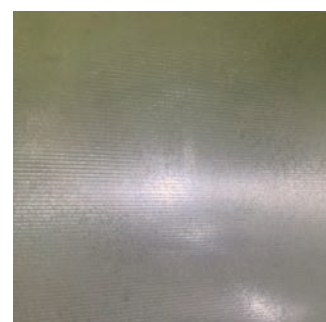

Illustration of a portion of the workpiece (4°horizontal slope)

Machined surface



Conventionally, after roughing was performed by a vertical machining center, the finished surface would be transferred to a horizontal machining center for finishing by face milling with the tooling block tilted at 4°. By using the lens type tool (PFB-LZ), work setup time is greatly reduced to achieve large cost reduction.



TAILORED SPECIAL TOOLS ARE AVAILABLE TO ACCOMMODATE SPECIFIC MACHINING REQUIREMENT.

| Appearance | Surface Treatment |
|--|---|
| <p>Example</p>  <p>Lens Type Insert : $\varnothing 16$ Bottom edge R60</p> <p>Oval Type Insert : $\varnothing 16$ Composite R40-R8</p>  <p>Oval Type End Mill</p>  <p>Barrel Type End Mill</p> | <p>Example</p>  <p>Diamond Coating</p> <p>DLC Coating</p> <p>Exchangeable Head End Mill</p> <p>Example</p>  <p>Barrel Type</p> <p>Lens Type</p> |

Please contact your local sales representative for details.

VU-R Series Variant Shape Tool for Finishing Website with CAD data for download

- DXF / STEP data conforming to ISO13399
- Accessible from desktop computers and smartphones

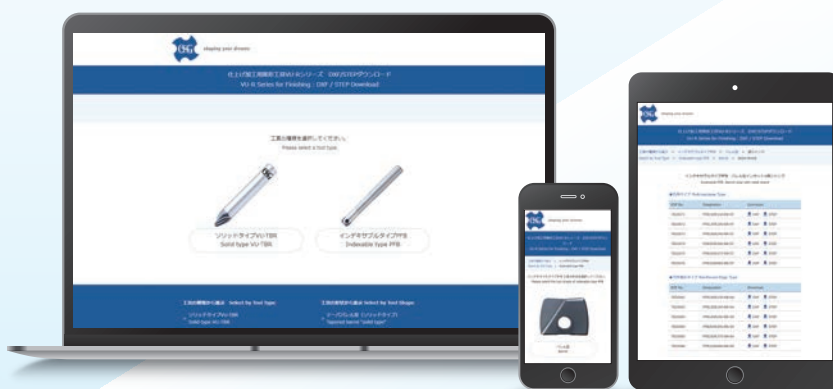

Visual image of CAD data

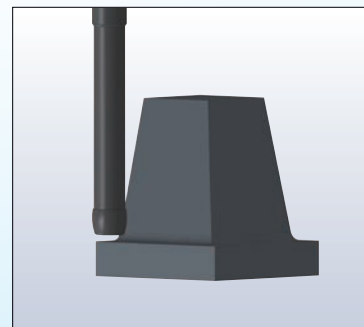

https://www.osg.co.jp/media_dl/vu-r_dl/

Easy access from QR code!



PFB-BR INSERTS

Milling | Indexables

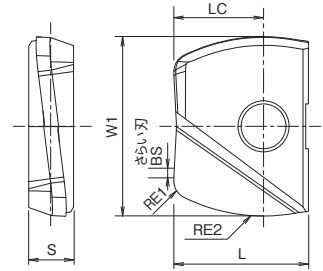

- Barrel type tool
- Contour milling of vertical slope
- Flat bottom milling
- 10 - 32 mm

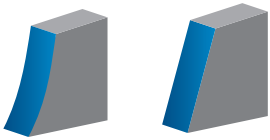

| EDP | Designation | ZEFP | W1 | RE2 | RE1 | LC | S | L | BS | Grade | P | | M | | K | | N | | S | | H | | Body size | Price |
|---------|------------------|------|----|------|-----|------|-----|------|-----|--------|-----|-----|-----|-----|----|-----|-----|-----|-----|-----|-----|-----|-----------|-------|
| | | | | | | | | | | | dry | oil | dry | oil | GG | GGG | dry | oil | dry | oil | dry | oil | | |
| 7820071 | PFB100R150-BR-ST | 2 | 10 | 15 | 1 | 5 | 2,6 | 8,5 | 0,3 | XP3225 | ● | ○ | ○ | | | | | | | | | | ③ | |
| 7820072 | PFB120R180-BR-ST | 2 | 12 | 18 | 1 | 6 | 3 | 10 | 0,3 | XP3225 | ● | ○ | ○ | | | | | | | | | | ④ | |
| 7820073 | PFB160R240-BR-ST | 2 | 16 | 24 | 2 | 8 | 4 | 12 | 0,5 | XP3225 | ● | ○ | ○ | | | | | | | | | | ⑤ | |
| 7820074 | PFB200R300-BR-ST | 2 | 20 | 30 | 2 | 10 | 5 | 15 | 0,5 | XP3225 | ● | ○ | ○ | | | | | | | | | | ⑥ | |
| 7820075 | PFB250R375-BR-ST | 2 | 25 | 37,5 | 2,5 | 12,5 | 6 | 18,5 | 0,5 | XP3225 | ● | ○ | ○ | | | | | | | | | | ⑦ | |
| 7820076 | PFB320R480-BR-ST | 2 | 32 | 48 | 3 | 16 | 7 | 23,5 | 0,5 | XP3225 | ● | ○ | ○ | | | | | | | | | | ⑨ | |
| 7820081 | PFB100R150-BR-SH | 2 | 10 | 15 | 1 | 5 | 2,6 | 8,5 | 0,3 | XP3310 | | | | | ● | ● | | | | | ● | | ③ | |
| 7820082 | PFB120R180-BR-SH | 2 | 12 | 18 | 1 | 6 | 3 | 10 | 0,3 | XP3310 | | | | | ● | ● | | | | | ● | | ④ | |
| 7820083 | PFB160R240-BR-SH | 2 | 16 | 24 | 2 | 8 | 4 | 12 | 0,5 | XP3310 | | | | | ● | ● | | | | | ● | | ⑤ | |
| 7820084 | PFB200R300-BR-SH | 2 | 20 | 30 | 2 | 10 | 5 | 15 | 0,5 | XP3310 | | | | | ● | ● | | | | | ● | | ⑥ | |
| 7820085 | PFB250R375-BR-SH | 2 | 25 | 37,5 | 2,5 | 12,5 | 6 | 18,5 | 0,5 | XP3310 | | | | | ● | ● | | | | | ● | | ⑦ | |
| 7820086 | PFB320R480-BR-SH | 2 | 32 | 48 | 3 | 16 | 7 | 23,5 | 0,5 | XP3310 | | | | | ● | ● | | | | | ● | | ⑨ | |

Milling | Indexables



PFB-LZ INSERTS

Milling | Indexables

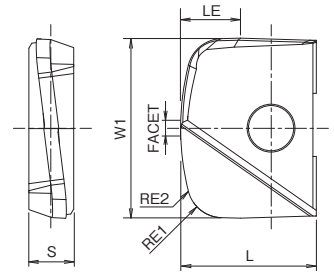

- Lens type tool
- Copy milling of horizontal slope
- Copy milling of curved surface
- 10 - 32 mm



| EDP | Designation | ZEFP | W1 | RE2 | RE1 | LC | S | L | BS | Grade | P | | M | | K | | N | | S | | H | | Body size | Price |
|---------|------------------|------|----|------|-----|------|-----|------|------|--------|-----|---|-----|---|----|-----|-----|---|-----|---|-----|---|-----------|-------|
| | | | | | | | | | | | dry | ⊕ | dry | ⊕ | GG | GGG | dry | ⊕ | dry | ⊕ | dry | ⊕ | | |
| 7820091 | PFB100R150-LZ-ST | 2 | 10 | 15 | 1 | 3.3 | 2.6 | 8.5 | 0.75 | XP3225 | ⊕ | | ⊕ | | | | | | | | | | ③ | |
| 7820092 | PFB120R180-LZ-ST | 2 | 12 | 18 | 1 | 4 | 3 | 10 | 0.75 | XP3225 | ⊕ | | ⊕ | | | | | | | | | | ④ | |
| 7820093 | PFB160R240-LZ-ST | 2 | 16 | 24 | 2 | 5.3 | 4 | 12 | 1 | XP3225 | ⊕ | | ⊕ | | | | | | | | | | ⑤ | |
| 7820094 | PFB200R300-LZ-ST | 2 | 20 | 30 | 2 | 6.7 | 5 | 15 | 1.75 | XP3225 | ⊕ | | ⊕ | | | | | | | | | | ⑥ | |
| 7820095 | PFB250R375-LZ-ST | 2 | 25 | 37.5 | 2.5 | 8.3 | 6 | 18.5 | 1.75 | XP3225 | ⊕ | | ⊕ | | | | | | | | | | ⑦ | |
| 7820096 | PFB320R480-LZ-ST | 2 | 32 | 48 | 3 | 10.7 | 7 | 23.5 | 2 | XP3225 | ⊕ | | ⊕ | | | | | | | | | | ⑨ | |
| 7820101 | PFB100R150-LZ-SH | 2 | 10 | 15 | 1 | 3.3 | 2.6 | 8.5 | 0.75 | XP3310 | | | | | ⊕ | ⊕ | | | | | | ⊕ | ③ | |
| 7820102 | PFB120R180-LZ-SH | 2 | 12 | 18 | 1 | 4 | 3 | 10 | 0.75 | XP3310 | | | | | ⊕ | ⊕ | | | | | | ⊕ | ④ | |
| 7820103 | PFB160R240-LZ-SH | 2 | 16 | 24 | 2 | 5.3 | 4 | 12 | 1 | XP3310 | | | | | ⊕ | ⊕ | | | | | | ⊕ | ⑤ | |
| 7820104 | PFB200R300-LZ-SH | 2 | 20 | 30 | 2 | 6.7 | 5 | 15 | 1.75 | XP3310 | | | | | ⊕ | ⊕ | | | | | | ⊕ | ⑥ | |
| 7820105 | PFB250R375-LZ-SH | 2 | 25 | 37.5 | 2.5 | 8.3 | 6 | 18.5 | 1.75 | XP3310 | | | | | ⊕ | ⊕ | | | | | | ⊕ | ⑦ | |
| 7820106 | PFB320R480-LZ-SH | 2 | 32 | 48 | 3 | 10.7 | 7 | 23.5 | 2 | XP3310 | | | | | ⊕ | ⊕ | | | | | | ⊕ | ⑨ | |



PFB SS

Milling | Indexables

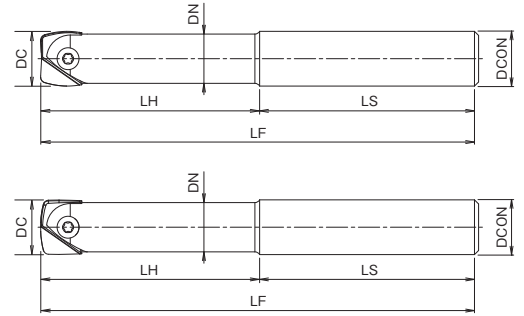
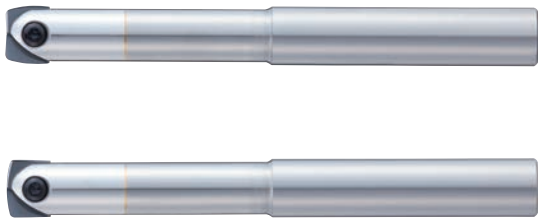

- Shank type
- 10 - 32 mm

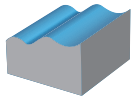

| EDP | Body size | Designation | ZEFP | DC | LF | LH | L/D | DCON | LS | DN | Specification | Price |
|---------|-----------|----------------------|------|----|-----|-------|-----|------|-------|----|---------------------------|-------|
| 7801401 | ③ | PFB-R100SS10-S130 | 2 | 10 | 130 | 45 | 4,5 | 10 | 85 | 9 | Steel shank | |
| 7801402 | ④ | PFB-R120SS12-S130 | 2 | 12 | 130 | 54 | 4,5 | 12 | 76 | 11 | Steel shank | |
| 7801403 | ⑤ | PFB-R160SS16-S140 | 2 | 16 | 140 | 64 | 4 | 16 | 76 | 14 | Steel shank | |
| 7801404 | ⑥ | PFB-R200SS20-S160 | 2 | 20 | 160 | 80 | 4 | 20 | 80 | 18 | Steel shank | |
| 7801405 | ⑦ | PFB-R250SS25-S160 | 2 | 25 | 160 | 75 | 3 | 25 | 85 | 22 | Steel shank | |
| 7801407 | ⑨ | PFB-R320SS32-S180 | 2 | 32 | 180 | 96 | 3 | 32 | 84 | 29 | Steel shank | |
| 7801431 | ③ | PFB-R100SS10-100CS | 2 | 10 | 100 | 25 | 2,5 | 10 | 75 | 9 | Carbide shank, Short | |
| 7801432 | ④ | PFB-R120SS12-110CS | 2 | 12 | 110 | 30 | 2,5 | 12 | 80 | 11 | Carbide shank, Short | |
| 7801433 | ⑤ | PFB-R160SS16-140CS | 2 | 16 | 140 | 40 | 2,5 | 16 | 100 | 14 | Carbide shank, Short | |
| 7801434 | ⑥ | PFB-R200SS20-160CS | 2 | 20 | 160 | 50 | 2,5 | 20 | 110 | 18 | Carbide shank, Short | |
| 7801435 | ⑦ | PFB-R250SS25-160CS | 2 | 25 | 160 | 62,5 | 2,5 | 25 | 97,5 | 22 | Carbide shank, Short | |
| 7801437 | ⑨ | PFB-R320SS32-180CS | 2 | 32 | 180 | 80 | 2,5 | 32 | 100 | 29 | Carbide shank, Short | |
| 7801441 | ③ | PFB-R100SS10-130CS | 2 | 10 | 130 | 50 | 5 | 10 | 80 | 9 | Carbide shank, Long | |
| 7801442 | ④ | PFB-R120SS12-140CS | 2 | 12 | 140 | 60 | 5 | 12 | 80 | 11 | Carbide shank, Long | |
| 7801443 | ⑤ | PFB-R160SS16-160CS | 2 | 16 | 160 | 72 | 4,5 | 16 | 88 | 14 | Carbide shank, Long | |
| 7801444 | ⑥ | PFB-R200SS20-180CS | 2 | 20 | 180 | 90 | 4,5 | 20 | 90 | 18 | Carbide shank, Long | |
| 7801445 | ⑦ | PFB-R250SS25-200CS | 2 | 25 | 200 | 100 | 4 | 25 | 100 | 22 | Carbide shank, Long | |
| 7801447 | ⑨ | PFB-R320SS32-230CS | 2 | 32 | 230 | 128 | 4 | 32 | 102 | 29 | Carbide shank, Long | |
| 7801421 | ③ | PFB-R100SS10-LL150CS | 2 | 10 | 150 | 70 | 7 | 10 | 80 | 9 | Carbide shank, Extra long | |
| 7801422 | ④ | PFB-R120SS12-LL160CS | 2 | 12 | 160 | 84 | 7 | 12 | 76 | 11 | Carbide shank, Extra long | |
| 7801423 | ⑤ | PFB-R160SS16-LL200CS | 2 | 16 | 200 | 96 | 6 | 16 | 104 | 14 | Carbide shank, Extra long | |
| 7801424 | ⑥ | PFB-R200SS20-LL240CS | 2 | 20 | 240 | 120 | 6 | 20 | 120 | 18 | Carbide shank, Extra long | |
| 7801425 | ⑦ | PFB-R250SS25-LL260CS | 2 | 25 | 260 | 137,5 | 5,5 | 25 | 122,5 | 22 | Carbide shank, Extra long | |
| 7801427 | ⑨ | PFB-R320SS32-LL300CS | 2 | 32 | 300 | 176 | 5,5 | 32 | 124 | 29 | Carbide shank, Extra long | |

Accessories & spare parts

| Applicable Body | Tightening torque (recommended) | Clamping screw | | Wrench | |
|-----------------|---------------------------------|----------------|-----------|----------------|-----------------|
| | | Clamping screw | Wrench | Clamping screw | Wrench |
| ③ | 1,2Nm | 7808117 | FS30686RB | 7808205 | T8-D (Torx 8) |
| ④ | 2Nm | 7808118 | FS35610RB | 7808207 | T10-D (Torx 10) |
| ⑤ | 3Nm | 7808119 | FS40613RB | 7808208 | T15-D (Torx 15) |
| ⑥ | 5Nm | 7808120 | FS50615RB | 7808209 | T20-D (Torx 20) |
| ⑦ | 5Nm | 7808121 | FS60620RB | 7808209 | T20-D (Torx 20) |
| ⑨ | 6Nm | 7808122 | FS80624RB | 7808212 | T30-T (Torx 30) |

Milling | Indexables

PFB SF SCREW FIT

Milling | Indexables

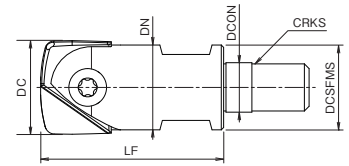
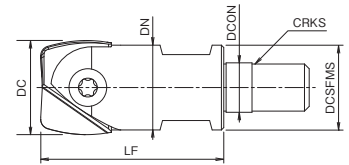

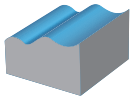

- Finishing ball end mill
- Excellent sharpness
- Screw fit type
- 10 - 25 mm



| EDP | Body size | Designation | ZEFP | DC | CRKS |  | LF | DN | DCSFMS | DCON | Price |
|---------|-----------|--------------|------|----|------|---|----|----|--------|------|-------|
| 7801490 | ③ | PFB-R100SF6 | 2 | 10 | 6 | 7 | 26 | 9 | 9 | 6,5 | |
| 7801491 | ④ | PFB-R120SF6 | 2 | 12 | 6 | 7 | 26 | 11 | 11 | 6,5 | |
| 7801492 | ⑤ | PFB-R160SF8 | 2 | 16 | 8 | 10 | 32 | 14 | 14,5 | 8,5 | |
| 7801493 | ⑥ | PFB-R200SF10 | 2 | 20 | 10 | 14 | 38 | 18 | 18 | 10,5 | |
| 7801494 | ⑦ | PFB-R250SF12 | 2 | 25 | 12 | 17 | 38 | 22 | 23 | 12,5 | |

Accessories & spare parts

| Applicable Body | Tightening torque (recommended) |  Clamping screw | |  Wrench | |
|-----------------|---------------------------------|--|-----------|--|-----------------|
| | | | | | |
| ③ | 1,2Nm | 7808117 | FS30686RB | 7808205 | T8-D (Torx 8) |
| ④ | 2Nm | 7808118 | FS35610RB | 7808207 | T10-D (Torx 10) |
| ⑤ | 3Nm | 7808119 | FS40613RB | 7808208 | T15-D (Torx 15) |
| ⑥ | 5Nm | 7808120 | FS50615RB | 7808209 | T20-D (Torx 20) |
| ⑦ | 5Nm | 7808121 | FS60620RB | 7808209 | T20-D (Torx 20) |
| ⑨ | 6Nm | 7808122 | FS80624RB | 7808212 | T30-T (Torx 30) |



CUTTING CONDITIONS

Milling | Indexables | Cutting conditions

PFB-BR

Barrel Type Tool

| | Work Material | Tensile Strength / Hardness | Milling Speed Vc (m/min) | Depth of Cut ap (mm) | fz (mm/t) | | |
|----------|---|-----------------------------|--------------------------|----------------------|-----------|---------|---------|
| | | | | | DC | | |
| | | | | | Ø 10,12 | Ø 16,20 | Ø 25-32 |
| P | Mild Steel-Carbon Steel (SS400-S10C) | ~180HB | 300 (200~400) | 0,2 D | 0,12 | 0,14 | 0,18 |
| | Carbon Steel-Alloy Steel (S50C-SCM440) | ~280HB | 300 (200~400) | 0,2 D | 0,1 | 0,12 | 0,14 |
| | Die Steel (SKD11-SKD61) | ~280HB | 250 (150~350) | 0,2 D | 0,1 | 0,12 | 0,14 |
| M | Stainless Steel (Dry) (SUS304-SUS420) | ~250HB | 250 (150~350) | 0,2 D | 0,12 | 0,14 | 0,17 |
| K | Cast Iron (FC250) | ~300N/mm ² | 400 (300~500) | 0,2 D | 0,14 | 0,18 | 0,22 |
| | Ductile Cast Iron (FCD400) | ~600N/mm ² | 300 (200~400) | 0,2 D | 0,12 | 0,14 | 0,18 |
| S | Heat Resistant Alloys (Wet) (Inconel 718) | - | 50 (25~80) | 0,15 D | 0,05 | 0,06 | 0,06 |
| | Titanium Alloy (Wet) (Ti-Al-4V) | - | 90 (40~120) | 0,2 D | 0,08 | 0,11 | 0,13 |
| H | Pre-hardened Steel (NAK80, STAVAX) | 40~43HRC | 200 (100~300) | 0,15 D | 0,07 | 0,08 | 0,1 |
| | Steel for Die Casting (DAC55-DH31) | 43~48HRC | 180 (90~200) | 0,15 D | 0,06 | 0,07 | 0,07 |
| | Hardened Steel (SKD11) | 50~60HRC | 150 (100~250) | 0,1 D | 0,06 | 0,07 | 0,07 |

The above cutting conditions are to be used as general guidelines. Adjustments may be necessary depending on actual cutting conditions.

Theoretical Cusp Height

(PFB-BR) Barrel Type Tool

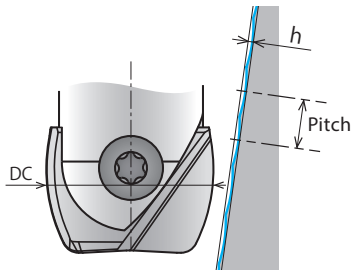

$$h = 0.5 \times (2 \times RE2 - \sqrt{(2 \times RE2)^2 - P^2})$$

h: Cusp height P: Pitch RE2: peripheral edge R

Cusp Height and Pitch

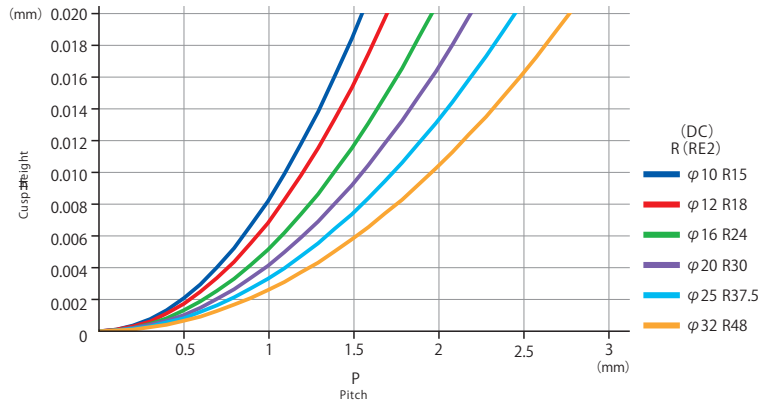

CUTTING CONDITIONS

Milling | Indexables | Cutting conditions

PFB-LZ

Lens Type Tool

| | Work Material | Tensile Strength / Hardness | Milling Speed Vc (m/min) | Depth of Cut ap (mm) | fz (mm/t) | | |
|----------|---|-----------------------------|--------------------------|----------------------|-----------|---------|---------|
| | | | | | DC | | |
| | | | | | Ø 10,12 | Ø 16,20 | Ø 25-32 |
| P | Mild Steel-Carbon Steel (S5400-S10C) | ~180HB | 300 (200~800) | 0,2 D | 0,12 | 0,14 | 0,18 |
| | Carbon Steel-Alloy Steel (S50C-SCM440) | ~280HB | 300 (200~800) | 0,2 D | 0,1 | 0,12 | 0,14 |
| | Die Steel (SKD11-SKD61) | ~280HB | 250 (150~600) | 0,2 D | 0,1 | 0,12 | 0,14 |
| M | Stainless Steel (Dry) (SUS304-SUS420) | ~250HB | 250 (150~650) | 0,2 D | 0,12 | 0,14 | 0,17 |
| K | Cast Iron (FC250) | ~300N/mm ² | 400 (300~800) | 0,2 D | 0,14 | 0,18 | 0,22 |
| | Ductile Cast Iron (FCD400) | ~600N/mm ² | 300 (200~800) | 0,2 D | 0,12 | 0,14 | 0,18 |
| S | Heat Resistant Alloys (Wet) (Inconel 718) | - | 50 (25~80) | 0,15 D | 0,05 | 0,06 | 0,06 |
| | Titanium Alloy (Wet) (Ti-Al-4V) | - | 90 (40~120) | 0,2 D | 0,08 | 0,11 | 0,13 |
| H | Pre-hardened Steel (NAK80, STAVAX) | 40~43HRC | 200 (100~350) | 0,15 D | 0,07 | 0,08 | 0,1 |
| | Steel for Die Casting (DAC55-DH31) | 43~48HRC | 180 (90~350) | 0,15 D | 0,06 | 0,07 | 0,07 |
| | Hardened Steel (SKD11) | 50~60HRC | 150 (100~300) | 0,1 D | 0,06 | 0,07 | 0,07 |

The above cutting conditions are to be used as general guidelines. Adjustments may be necessary depending on actual cutting conditions.

Theoretical Cusp Height

(PFB-LZ) Len Type Tool

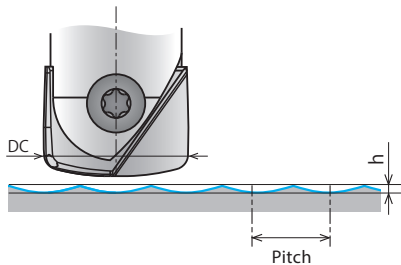

$$h = 0.5 \times (2 \times RE2 - \sqrt{(2 \times RE2)^2 - P^2})$$

h: Cusp height P: Pitch RE2: peripheral edge R

Cusp Height and Pitch

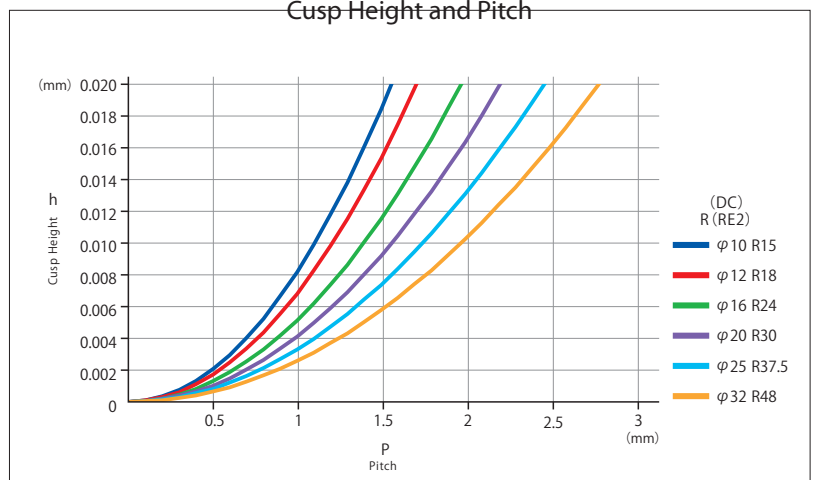

Taper Barrel Type End Mill

Achieves greater processing efficiency by the large peripheral edge R and multi-flute specification

Taper Barrel Type VU-TBR

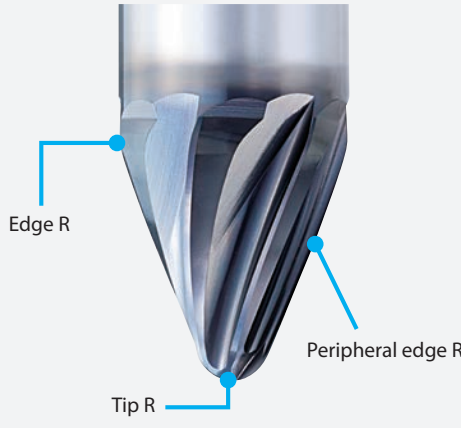

- Contour milling of vertical slope
- 20° tool tilt angle

Multi-flute specification for higher processing efficiency

Highly efficient finishing

With the same cusp height

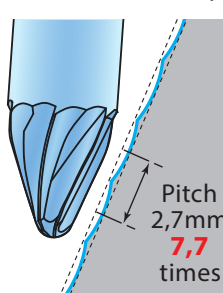

Pitch 2,7mm

Example

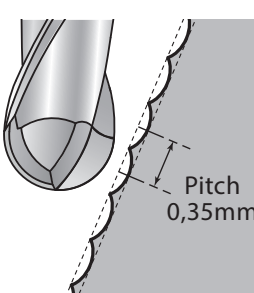

Pitch 0,35mm

← High efficiency

0,003 mm

The large Peripheral edge R allows the cusp height to be kept at a minimum level even when the pitch is increased.

High efficiency 5-axis machining on vertical slope

| Tool | VU-TBR | Conventional Ball End Mill |
|-------------------|-------------------------------------|------------------------------------|
| Size | R1,5 x R300 x 20° | R5 |
| Number of flutes | 4 flutes | 2 flutes |
| Work Material | NAK80 (40HRC) | |
| Cutting Speed | 233m/min (11.937min ⁻¹) | 282m/min (9.549min ⁻¹) |
| Feed Rate | 955mm/min (0,2 mm/t) | 764mm/min (0,04 mm/t) |
| Pitch | 2,7mm | 0,34mm |
| Depth of Cut | 0,3mm | |
| Overhang Length | 35mm | |
| Cusp height | 0,003mm | |
| Surface Roughness | Ra=0.12µm Rz=1.39µm | Ra=0.61µm Rz=2.59µm |
| Machining surface | Set to almost the same cusp height | |
| Coolant | Dry | |
| Machine | 5-axis machining center (BT50) | |

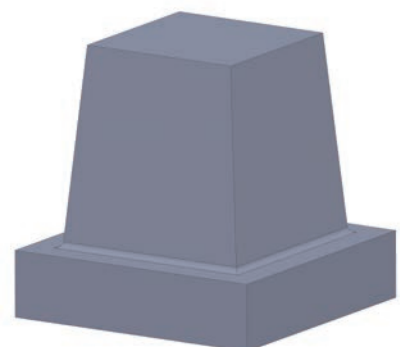

By increasing the pitch with a large radius and increasing the feed rate, approximately 10 times the efficiency is achieved.



VU-TBR NEW

Milling | Solid carbide



4-Flutes



6-Flutes

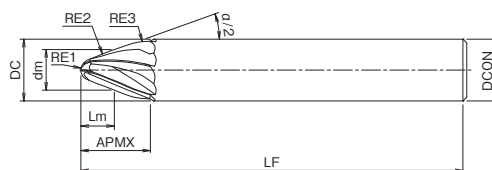

- Taper Barrel Solid Type
- High-efficiency multi-flute specification
- 4-6 flutes

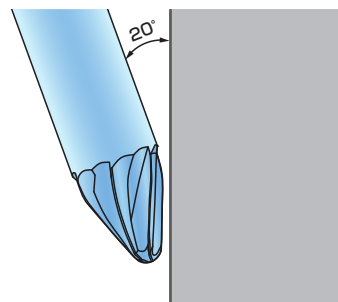

When using the peripheral edge R (RE2), set the tilt angle ($\alpha/2$) to 20°.



| EDP | ZEFP | RE1 X RE2 X $\alpha/2$ | Tilt $\alpha/2$ | DC | Tip RE1 | Tip RE2 | Tip RE3 | Lm | dm | LF | APMX | DCON | Price |
|---------|------|------------------------|-----------------|----|---------|---------|---------|------|-------|-----|------|------|-------|
| 8549544 | 4 | R0,5 × R150 × 20° | 20° | 6 | 0,5 | 150 | 5 | 3,43 | 3,27 | 50 | 8,2 | 6 | |
| 8549545 | 4 | R1 × R150 × 20° | 20° | 8 | 1 | 150 | 5 | 4,48 | 4,78 | 60 | 9,9 | 8 | |
| 8549546 | 4 | R1,5 × R300 × 20° | 20° | 10 | 1,5 | 300 | 5 | 5,52 | 6,2 | 70 | 11,7 | 10 | |
| 8549547 | 6 | R2 × R300 × 20° | 20° | 12 | 2 | 300 | 5 | 6,57 | 7,7 | 80 | 13,5 | 12 | |
| 8549548 | 6 | R2,5 × R500 × 20° | 20° | 16 | 2,5 | 500 | 5 | 8,99 | 10,18 | 100 | 18 | 16 | |
| 8549549 | 6 | R3 × R500 × 20° | 20° | 16 | 3 | 500 | 5 | 8,67 | 10,62 | 100 | 17,1 | 16 | |



CUTTING CONDITIONS

Milling | Indexables | Cutting conditions

VU-TBR

Using peripheral edge R (RE2)

| Vc | Carbon Steel • Alloy Steel S55C • SCM • SKT | | | | Hardened Steel • Prehardened Steel SKT • SKD • NAK55 • HPM1 | | | | Hardened Steel • Prehardened Steel | | | |
|-------------------|--|---------------|---|----------------------|--|---------------|---|----------------------|------------------------------------|---------------|---|----------------------|
| | ~30HRC | | | | 30~45HRC | | | | 45~55HRC | | | |
| ∅ | S (min ⁻¹) | F (mm/min) | Pitch | Depth of Cut (mm) | S (min ⁻¹) | F (mm/min) | Pitch | Depth of Cut (mm) | S (min ⁻¹) | F (mm/min) | Pitch | Depth of Cut (mm) |
| R0,5 × R150 × 20° | 10.700 | 3.400 | Based on Cusp height (see chart below) | 0,3 | 8.800 | 2.500 | Based on Cusp height (see chart below) | 0,3 | 6.800 | 1.600 | Based on Cusp height (see chart below) | 0,3 |
| R1 × R150 × 20° | 7.300 | 2.300 | | 0,3 | 6.000 | 1.700 | | 0,3 | 4.700 | 1.100 | | 0,3 |
| R1,5 × R300 × 20° | 5.600 | 1.800 | | 0,3 | 4.600 | 1.300 | | 0,3 | 3.600 | 900 | | 0,3 |
| R2 × R300 × 20° | 4.500 | 2.200 | | 0,3 | 3.700 | 1.600 | | 0,3 | 2.900 | 1.000 | | 0,3 |
| R2,5 × R500 × 20° | 3.400 | 1.600 | | 0,3 | 2.800 | 1.200 | | 0,3 | 2.200 | 800 | | 0,3 |
| R3 × R500 × 20° | 3.300 | 1.600 | | 0,3 | 2.700 | 1.100 | | 0,3 | 2.100 | 800 | | 0,3 |

1. Use a rigid and precise machine and holder.
2. Use a coolant with low air-blow or fuming property according to the work material. MQL (oil mist coolant) is recommended for cutting hardened steels.
3. "Using tip R (RE1)" is the guide to use the tip R. Please adjust the rotation speed, feed rate and cutting pitch based on the cutting shape, machine rigidity, workpiece and holding conditions.
4. When chattering, vibration or abnormal cutting noise occurs, please adjust the rotation speed, feed rate and cutting pitch.
5. In order to change the rotation speed, both the rotation speed and the feed rate should be changed at the same ratio.

Theoretical Cusp Height

(VU-TBR) Taper Barrel Type

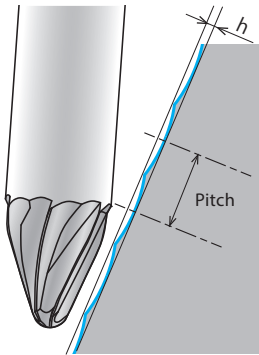

$$h = 0.5 \times \left(2 \times RE2 - \sqrt{(2 \times RE2)^2 - P^2} \right)$$

h: Cusp height P: Pitch RE2: peripheral edge R

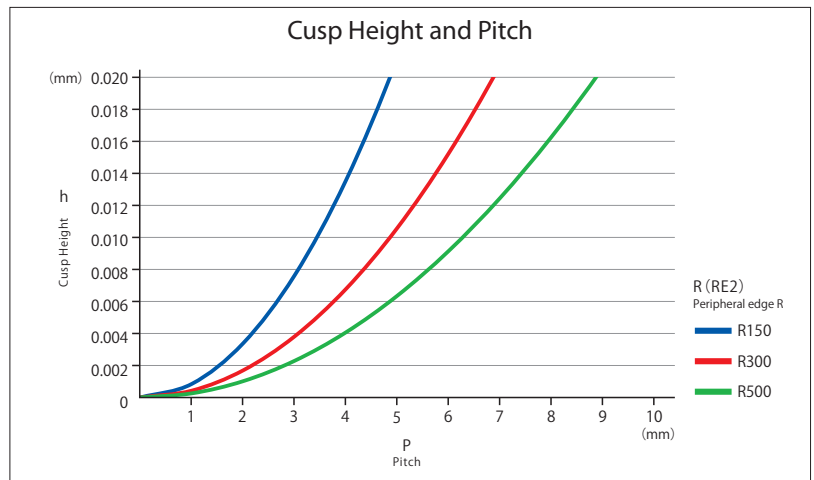

CUTTING CONDITIONS

Milling | Indexables | Cutting conditions

VU-TBR

Using Tip R (RE1)

| Vc | Carbon Steel • Alloy Steel S55C • SCM • SKT | | | | Hardened Steel • Prehardened Steel SKT • SKD • NAK55 • HPM1 | | | | Hardened Steel • Prehardened Steel 45~55HRC | | | |
|-------------------|--|------------|--|-------------------|--|------------|--|-------------------|--|------------|--|-------------------|
| | S (min ⁻¹) | F (mm/min) | Pitch | Depth of Cut (mm) | S (min ⁻¹) | F (mm/min) | Pitch | Depth of Cut (mm) | S (min ⁻¹) | F (mm/min) | Pitch | Depth of Cut (mm) |
| ~30HRC | | | | | 30~45HRC | | | | 45~55HRC | | | |
| ∅ | S (min ⁻¹) | F (mm/min) | Pitch | Depth of Cut (mm) | S (min ⁻¹) | F (mm/min) | Pitch | Depth of Cut (mm) | S (min ⁻¹) | F (mm/min) | Pitch | Depth of Cut (mm) |
| R0,5 × R150 × 20° | 19.500 | 6.200 | Based on Cusp height (see chart below) | ~0,1 | 15.600 | 4.400 | Based on Cusp height (see chart below) | ~0,1 | 13.600 | 3.300 | Based on Cusp height (see chart below) | ~0,1 |
| R1 × R150 × 20° | 13.000 | 4.300 | | ~0,2 | 10.700 | 3.000 | | ~0,2 | 9.300 | 2.200 | | ~0,2 |
| R1,5 × R300 × 20° | 10.300 | 3.300 | | ~0,25 | 8.200 | 2.300 | | ~0,25 | 7.200 | 1.700 | | ~0,25 |
| R2 × R300 × 20° | 8.300 | 4.000 | | ~0,3 | 6.600 | 2.800 | | ~0,3 | 5.800 | 2.100 | | ~0,3 |
| R2,5 × R500 × 20° | 6.300 | 3.000 | | ~0,3 | 5.000 | 2.100 | | ~0,3 | 4.400 | 1.600 | | ~0,3 |
| R3 × R500 × 20° | 6.000 | 2.900 | | ~0,3 | 4.800 | 2.000 | | ~0,3 | 4.200 | 1.500 | | ~0,3 |

1. Use a rigid and precise machine and holder.
2. Use a coolant with low air-blow or fuming property according to the work material. MQL (oil mist coolant) is recommended for cutting hardened steels.
3. "Using tip R (RE1)" is the guide to use the tip R. Please adjust the rotation speed, feed rate and cutting pitch based on the cutting shape, machine rigidity, workpiece and holding conditions.
4. When chattering, vibration or abnormal cutting noise occurs, please adjust the rotation speed, feed rate and cutting pitch.
5. In order to change the rotation speed, both the rotation speed and the feed rate should be changed at the same ratio.

Theoretical Cusp Height

(VU-TBR) Taper Barrel Type

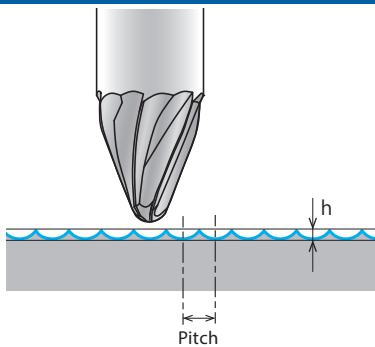

$$h = 0.5 \times (2 \times RE1 - \sqrt{(2 \times RE1)^2 - P^2})$$

h: Cusp height P: Pitch RE1: peripheral edge R

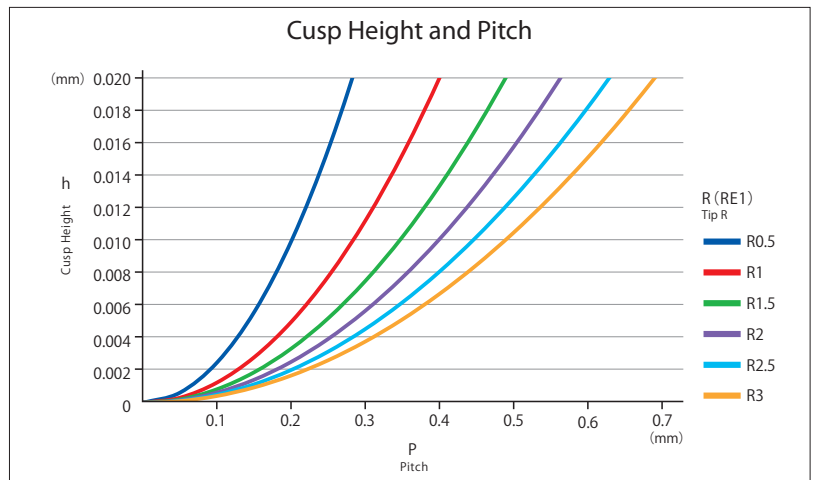

Oval Shape End Mill

Further flexibility to your material removal on the complex shape.

Suitable for overall finishing of standing walls including gentle curved surfaces and corner radius. Able to adjust contacting point and avoid chattering.

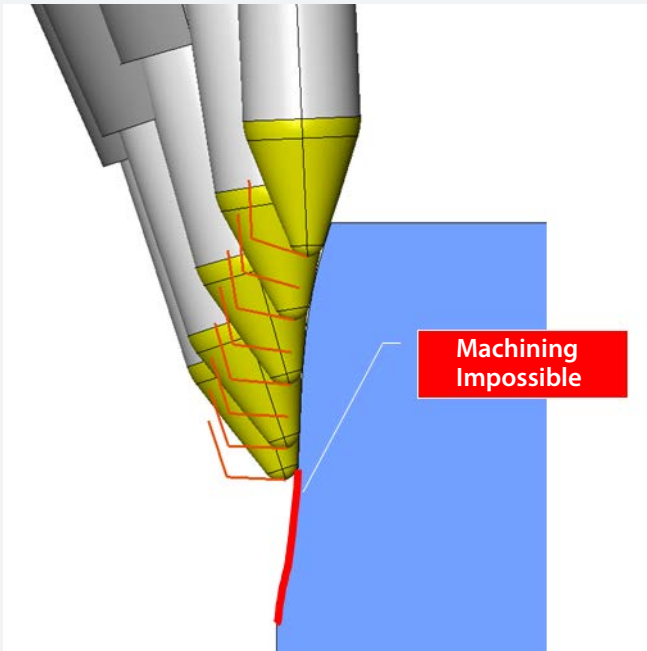
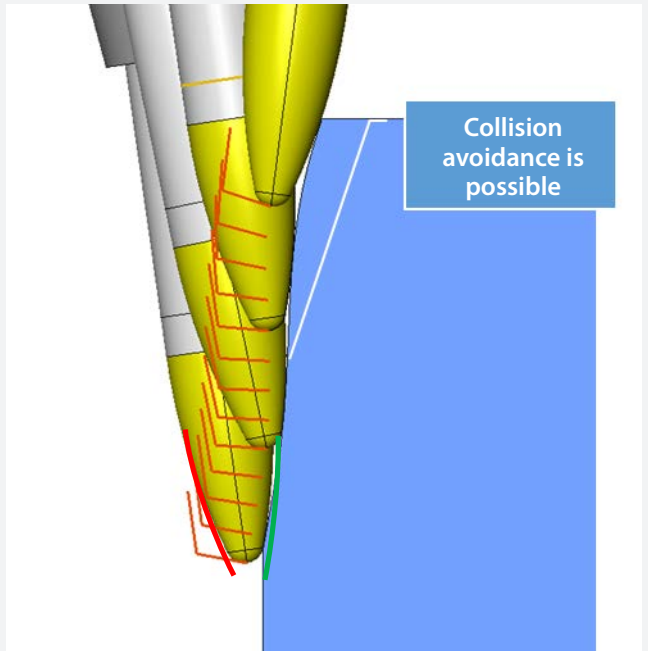
| End mill form comparison | |
|---|--|
| Taper Barrel Type (VU-TBR) | Oval Type (VU-EGG) |
|  |  |
| <ul style="list-style-type: none">• Bigger peripheral radius can improve the productivity and surface finish.• Efficient for flat surface, but not suitable for complex curving surface. | <ul style="list-style-type: none">• Oval type works better if the work piece has a non-linear surface.• The end mill may require a suitable CAM software support. |



VU-EGG NEW

Milling | Solid carbide

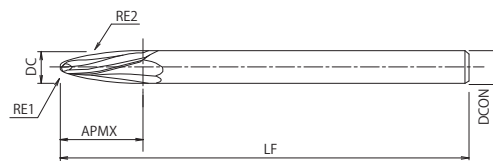

- Oval shape Type
- For General steel, WXL coating
- 2 flutes



| EDP | ZEFP | DC | Tip RE1 | Tip RE2 | LF | APMX | DCON | Price |
|----------|------|----|---------|---------|-----|--------|------|-------|
| W1901274 | 2 | 8 | 1,5 | 50 | 100 | 16,876 | 8 | |
| | | | | | | | | |
| | | | | | | | | |

VU-EGG-H NEW

Milling | Solid carbide



- Oval shape Type
- For Hardened material, Durorey coating
- 2 flutes



| EDP | ZEFP | DC | Tip RE1 | Tip RE2 | LF | APMX | DCON | Price |
|----------|------|----|---------|---------|-----|--------|------|-------|
| W1901273 | 2 | 8 | 1,5 | 50 | 100 | 16,876 | 8 | |
| | | | | | | | | |
| | | | | | | | | |



CUTTING CONDITIONS

Milling | Indexables | Cutting conditions

VU-EGG-(H)

Using peripheral edge R (RE2)

| | Carbon Steel • Alloy Steel S55C • SCM • SKT | | | | Hardened Steel • Prehardened Steel SKT • SKD • NAK55 • HPM1 | | | | Hardened Steel • Prehardened Steel | | | | Hardened Steel • Prehardened Steel <small>Only VU-EGG-H only, not recommendable for VU-EGG</small> | | | | | | | |
|----------|--|---------------|--|----------------------|--|---------------|--|----------------------|------------------------------------|---------------|--|----------------------|---|---------------|--|----------------------|--|--|--|--|
| Vc | ~30HRC | | | | 30~45HRC | | | | 45~55HRC | | | | 55~62HRC | | | | | | | |
| Ø | S (min ⁻¹) | F (mm/min) | Pitch | Depth of Cut (mm) | S (min ⁻¹) | F (mm/min) | Pitch | Depth of Cut (mm) | S (min ⁻¹) | F (mm/min) | Pitch | Depth of Cut (mm) | S (min ⁻¹) | F (mm/min) | Pitch | Depth of Cut (mm) | | | | |
| R1,5XR50 | 7.300 | 1.400 | Based on Cusp height (see chart below) | 0,3 | 6.000 | 1.100 | Based on Cusp height (see chart below) | 0,3 | 4.700 | 700 | Based on Cusp height (see chart below) | 0,3 | 4.000 | 500 | Based on Cusp height (see chart below) | 0,3 | | | | |
| | | | | | | | | | | | | | | | | | | | | |
| | | | | | | | | | | | | | | | | | | | | |

1. Use a rigid and precise machine and holder.
2. Use a coolant with low air-blow or fuming property according to the work material. MQL (oil mist coolant) is recommended for cutting hardened steels.
3. "Using tip R (RE1)" is the guide to use the tip R. Please adjust the rotation speed, feed rate and cutting pitch based on the cutting shape, machine rigidity, workpiece and holding conditions.
4. When chattering, vibration or abnormal cutting noise occurs, please adjust the rotation speed, feed rate and cutting pitch.
5. In order to change the rotation speed, both the rotation speed and the feed rate should be changed at the same ratio.

Theoretical Cusp Height

(VU-EGG) Oval shape end-mill

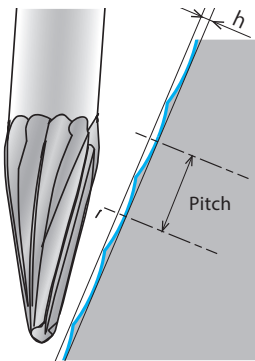

$$h = 0.5 \times \left(2 \times RE2 - \sqrt{(2 \times RE2)^2 - P^2} \right)$$

h: Cusp height P: Pitch RE2: peripheral edge R

Cusp Height and Pitch

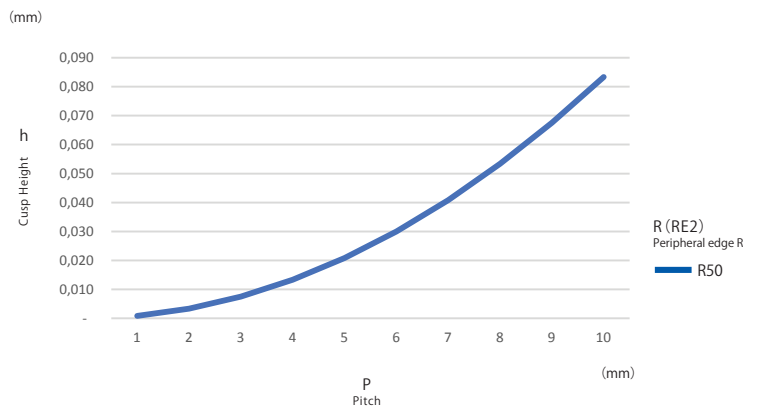

CUTTING CONDITIONS

Milling | Indexables | Cutting conditions

VU-EGG-(H)

Using Tip R (RE1)

| Vc | Carbon Steel • Alloy Steel S55C • SCM • SKT | | | | Hardened Steel • Prehardened Steel SKT • SKD • NAK55 • HPM1 | | | | Hardened Steel • Prehardened Steel | | | | Hardened Steel • Prehardened Steel <small>Only VU-EGG-H only, not recommendable for VU-EGG</small> | | | |
|----------|--|---------------|--|----------------------|--|---------------|--|----------------------|------------------------------------|---------------|--|----------------------|---|---------------|--|----------------------|
| | ~30HRC | | | | 30~45HRC | | | | 45~55HRC | | | | 55~62HRC | | | |
| Ø | S (min ⁻¹) | F (mm/min) | Pitch | Depth of Cut (mm) | S (min ⁻¹) | F (mm/min) | Pitch | Depth of Cut (mm) | S (min ⁻¹) | F (mm/min) | Pitch | Depth of Cut (mm) | S (min ⁻¹) | F (mm/min) | Pitch | Depth of Cut (mm) |
| R1,5XR50 | 10.300 | 1.900 | Based on Cusp height (see chart below) | ~ 0,25 | 8.200 | 1.300 | Based on Cusp height (see chart below) | ~ 0,25 | 7.200 | 1.000 | Based on Cusp height (see chart below) | ~ 0,25 | 6.100 | 610 | Based on Cusp height (see chart below) | ~ 0,25 |
| | | | | | | | | | | | | | | | | |

1. Use a rigid and precise machine and holder.
2. Use a coolant with low air-blow or fuming property according to the work material. MQL (oil mist coolant) is recommended for cutting hardened steels.
3. "Using tip R (RE1)" is the guide to use the tip R. Please adjust the rotation speed, feed rate and cutting pitch based on the cutting shape, machine rigidity, workpiece and holding conditions.
4. When chattering, vibration or abnormal cutting noise occurs, please adjust the rotation speed, feed rate and cutting pitch.
5. In order to change the rotation speed, both the rotation speed and the feed rate should be changed at the same ratio.

Theoretical Cusp Height

(VU-EGG-H) Oval Type

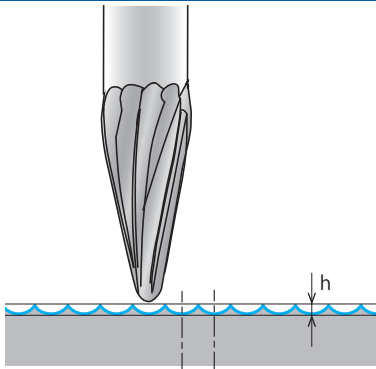

$$h = 0.5 \times (2 \times RE1 - \sqrt{(2 \times RE1)^2 - P^2})$$

h: Cusp height P: Pitch RE1: peripheral edge R

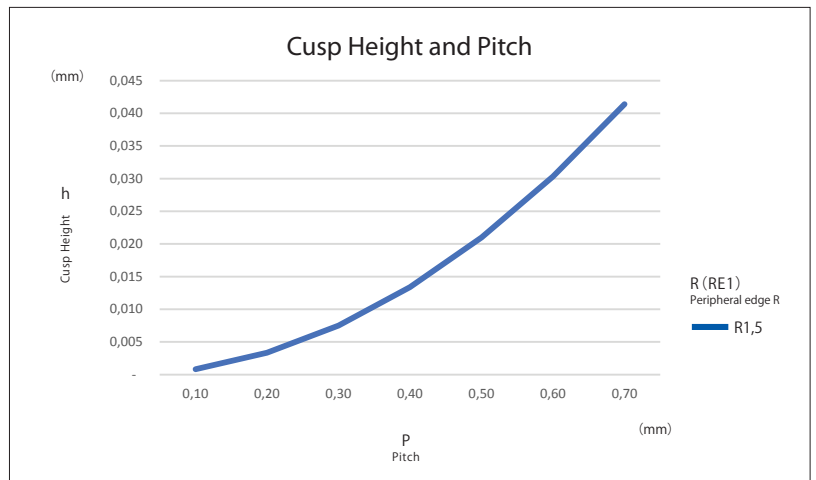

BALL END MILL PFB FOR FINISHING

Composite Radius Shape Type Variant Shape Tool

PolyBall

Finishing by PolyBall

PAT.P in JAPAN

A major feature is that it can be used just like any ball end mill.

Improves machined surface quality and reduces machining time complex shapes such as inclined and curved surfaces.



Even with the same $\phi 20$ tool, a typical ball end mill would have a R10-edge whereas the PolyBall is constructed with a R30-edge. As a result, the cusp height can be kept small even if the pitch becomes larger, enabling high precision machining in shorter time.

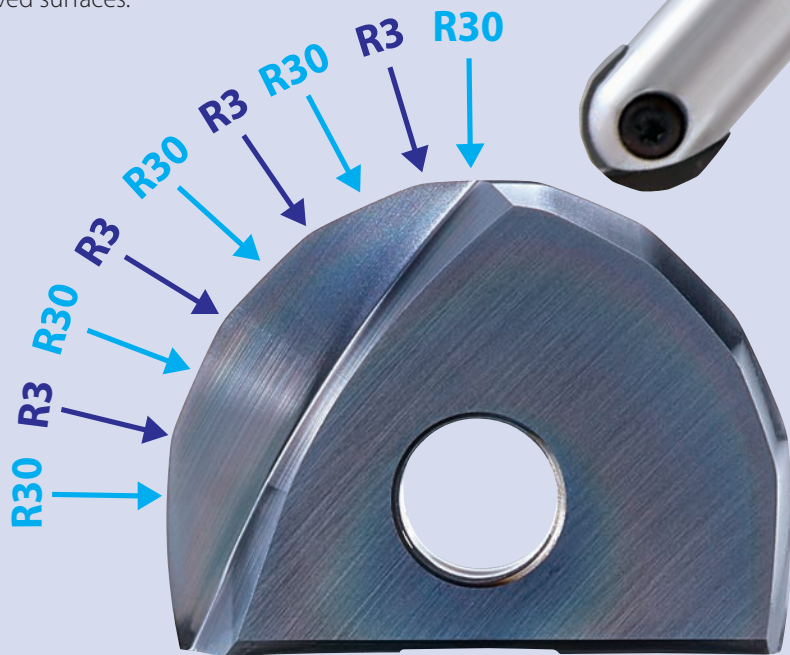

Example of combination of RS

Compatible with various inclined surfaces

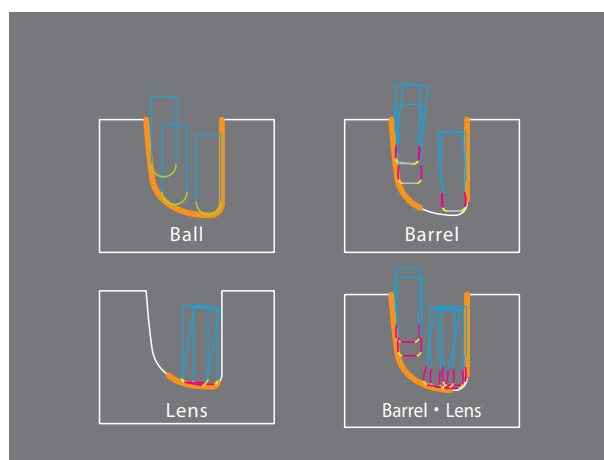
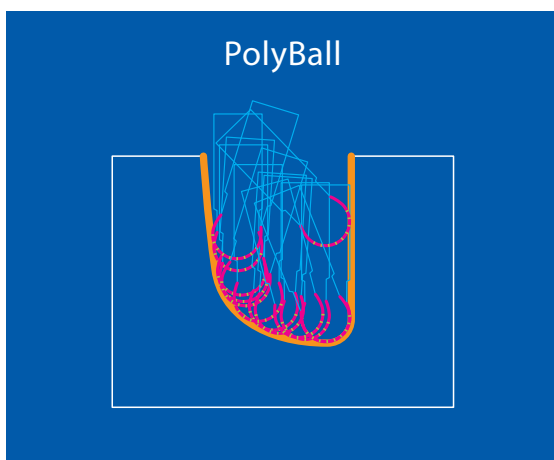

Machined area

Tailored special tools are available to accommodate specific machining requirement. Please contact your sales representative for details.



CUTTING DATA

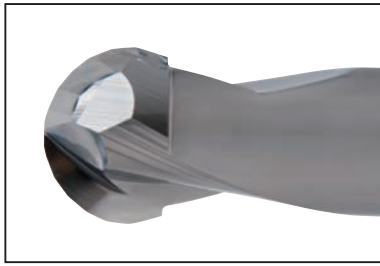

Solid PolyBall
Ø12 R60-R6

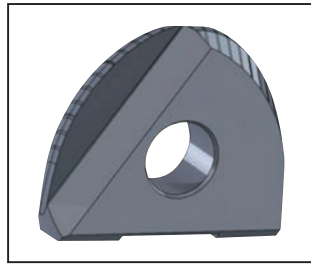

PFB PolyBall
Ø12 R24-R6

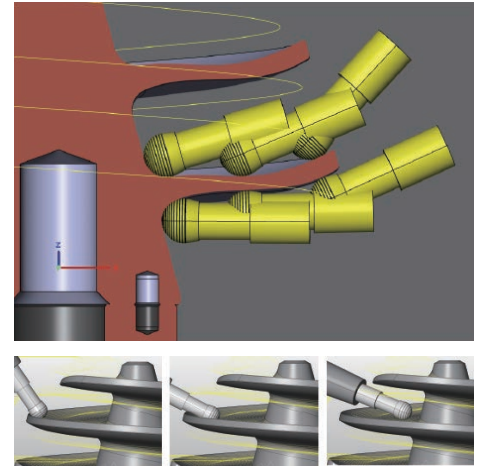

Work Material: A7075 T651
Machine: 5-axis Machining center (HSK63)
Coolant: Non-water-soluble coolant

| Process | Tool | Cutting Method | Cutting Speed | Feed | Depth of Cut | Overhang Length | Stock to |
|---------|------------------------------|--|--|---------------------------|---------------------------------------|-----------------|----------|
| ① | CA-PKE | Roughing | 490m/min (13.000min ⁻¹) | 8.000mm/min (0,21mm/t) | ap: 1,5mm ae: 8mm | 65mm | 0,4mm |
| ② | Solid Polyball Ø12 R60-R6 | Semi-finishing of blade face and edge | 317m/min (8.400min ⁻¹) | 3.000mm/min (0,18mm/t) | Pitch: 4mm Depth of cut: 2mm | 40mm | 0,1mm |
| ③ | Solid Polyball Ø12 R24-R6 | Finishing of blade face | 414m/min (11.000min ⁻¹) | 1.700mm/min (0,08mm/t) | Pitch: 0,5mm Depth of cut: 0,5mm | 42mm | - |
| ④ | DLC-EBD R4 | Semi-finishing of blade edge, hub face and fillet part | 200m/min (8.000min ⁻¹) | 2.400mm/min (0,15mm/t) | Pitch: 0,7mm Depth of cut: 0,5mm | 42mm | 0,15mm |
| ⑤ | DLC-EBD R4 | Finishing of blade edge, hub face and fillet part | 200m/min (8.000min ⁻¹) | 2.400mm/min (0,15mm/t) | Pitch: 0,18mm Depth of cut: 0,18mm | 42mm | - |

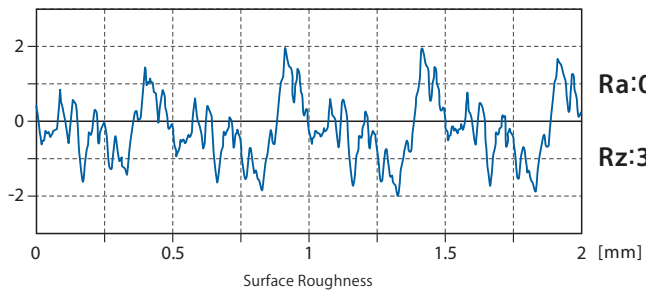

SWEDEN

Branch office of OSG SCANDINAVIA
Abrahams Gränd 8
295 35 Bromölla
Sweden
Tel: +46 40 41 22 55
osg@osg-scandinavia.com

OSG SCANDINAVIA

(For Scandinavian countries)
Langebjergvaenget 16
4000 Roskilde
Denmark
Tel: +45 46 75 65 55
osg@osg-scandinavia.com

OSG NETHERLANDS

Bedrijfsweg 5
3481 MG Harmelen
The Netherlands
Tel: +31 348 44 2764
Fax: +31 348 44 2144
info@osg-nl.com

OSG UK

Shelton house, 5 Bentalls
Pipps Hill Ind Est, Basildon Essex SS14 3BY
United Kingdom
Tel: +44 1268 567660
Fax: +44 1268 567661
sales@osg-uk.com

OSG EUROPE LOGISTICS

Avenue Lavoisier 1
B-1300 Z.I. Wavre - Nord
Belgium
Tel: +32 10 23 05 07
Fax: +32 10 23 05 51
info@osgeurope.com

OSG BELUX

Avenue Lavoisier 1
B-1300 Z.I. Wavre - Nord
Belgium
Tel: +32 10 23 05 11
Fax: +32 10 23 05 31
info@osg-belgium.com

OSG IBÉRICA

Bekolarra 4
E - 01010 Vitoria-Gasteiz
Spain
Tel: +34 945 242 400
Fax: +34 945 228 883
osg.iberica@osg-ib.com

OSG FRANCE

Parc Icade, Paris Nord 2
Immeuble "Le Rimbaud"
22 Avenue des Nations
CS66191 - 93420 Villepinte
France
Tel: +33 1 49 90 10 10
Fax: +33 1 49 90 10 15
sales@osg-france.com

OSG ITALY

Via Ferrero, 65 A/B
I - 10098 Rivoli
Italian
Tel: +39 0117705211
Fax: +39 0117705215
info@osg-italia.it



OSG IN EUROPE

CZECH REPUBLIC, SLOVAKIA, HUNGARY

OSG Europe Logistics S. A.
Slovakia, organizačná zložka
Račianska 22/A, Bratislava 831 02
Slovakia
Tel.: +421 24 32 91 295
info@osgeurope.com

OSG POLAND

ul. Spółdzielcza 57
05-074 Halinów
Polska
Tel: +22 760 82 71
Mob. +48 570 677 711
osg@osg-poland.com

OSG RUSSIA

Butlerova street, 17B, office 5069
117342 Moscow
Russia
Tel: +7 (495) 150 41 54
info@osg-russia.com

ROMSAN INTERNATIONAL CO. SRL

Reprezentant Exclusiv OSG
25C, Bucuresti-Magurele Street
051431 Bucuresti
România
Tel: +40 21 322 07 47
Fax: +40 21 321 56 00
romsan.int@romsan.ro

OSG TURKEY

Rami Kışla Cad.No:56 Eyüp
Istanbul 34056
Turkey
Tel: +90 212 565 24 00
Fax: +90 212 565 44 00
info@osg-turkey.com

Vischer & Bolli AG

Machining and Workholding
Im Schossacher 17
CH-8600 Dübendorf
Schweiz
Tel.: +41 44 802 15 15
Fax: +41 44 802 15 95
info@vb-tools.com

OSG GERMANY

Karl-Ehmann-Str. 25
D - 73037 Göppingen
Germany
Tel: +49 7161 6064 - 0
Fax: +49 7161 6064 - 444
info@osg-germany.de



shaping your dreams

OSG EUROPE LOGISTICS

Avenue Lavoisier 1
B-1300 Z.I. Wavre - Nord - Belgium
Tel: +32 10 23 05 07
Fax: +32 10 23 05 51
info@osgeurope.com

OSG BELUX

Avenue Lavoisier 1
B-1300 Z.I. Wavre - Nord - Belgium
Tel: +32 10 23 05 11
Fax: +32 10 23 05 31
info@osg-belgium.com

OSG FRANCE

Parc Icade, Paris Nord 2
Immeuble "Le Rimbaud"
22 Avenue des Nations
CS66191 - 93420 Villepinte - France
Tel: +33 1 49 90 10 10
Fax: +33 1 49 90 10 15
sales@osg-france.com

OSG NETHERLANDS

Bedrijfsweg 5 - 3481 MG Harmelen
Tel: +31 348 44 2764
Fax: +31 348 44 2144
info@osg-nl.com

OSG UK

Shelton house, 5 Bentalls
Pipps Hill Ind Est, Basildon Essex SS14 3BY
Tel: +44 1268 567 660
Fax: +44 1268 567 661
sales@osg-uk.com

CZECH, SLOVAKIA, HUNGARY

OSG Europe Logistics S.A.
Slovakia organizacna zlozka
Racianská 22/A, SK-83102 Bratislava
Slovakia
Tel. +421 24 32 91 295
Orders-osgsvk@osgeurope.com

OSG POLAND Sp. z.o.o.

Spółdzielcza 57
05-074 Halinów - Poland
Tel: +22 760 82 71
Fax: +22 760 82 71
osg@osg-poland.com

OSG GERMANY

Karl-Ehmann-Str. 25
D - 73037 Göppingen - Germany
Tel: +49 7161 6064 - 0
Fax: +49 7161 6064 - 444
info@osg-germany.de

OSG SCANDINAVIA

(For Scandinavian countries)
Langebjergvaenget 16
4000 Roskilde - Denmark
Tel: +45 46 75 65 55
Fax: +45 46 75 67 00
osg@osg-scandinavia.com

SWEDEN

Branch office of OSG SCANDINAVIA
Abrahams Gränd 8
295 35 Bromölla - Sweden
Tel: +46 40 41 22 55
Fax: +46 40 41 32 55
osg@osg-scandinavia.com

OSG IBERICA

Bekolarra 4
E - 01010 Vitoria-Gasteiz - Spain
Tel: +34 945 242 400
Fax: +34 945 228 883
osg.iberica@osg-ib.com

RUSSIA

Butlerova street, 17B, office 5069
117342 Moscow - Russia
Tel: +7 (495) 150 41 54
info@osg-russia.com

OSG TURKEY

Rami Kişla Cad.No:56 Eyüp
Istanbul 34056 - Turkey
Tel:+90 212 565 24 00
Fax: +90 212 565 44 00
info@osg-turkey.com

ROMSAN INTERNATIONAL CO. SRL

Reprezentant Exclusiv OSG
25C, Bucuresti-Magurele Street
051431 Bucuresti - România
Tel: +40 21 322 07 47
Fax: +40 21 321 56 00
romsan.int@romsan.ro

AUSTRIA

Branch office of OSG GERMANY
Messestraße 11
A-6850 Dornbirn
Tel: +49 7161 6064-0
Fax: + 49 7161 6064-444
info@osg-germany.de

OSG ITALIA

Via Ferrero, 65 A/B
I - 10098 Rivoli - Italy
Tel: +39 0117705211
Fax: +39 0117705215
info@osg-italia.it

Vischer & Bolli AG

Machining and Workholding
Im Schossacher 17
CH-8600 Dübendorf
T +41 44 802 15 15
F +41 44 802 15 95
info@vb-tools.com

OSG EUROPE LOGISTICS S.A.

06/2020 - All rights reserved. © OSG Europe 2020.

The contents of this catalogue are provided to you for viewing only. They are not intended for reproduction either in part or in whole in this or other medium. They cannot be copied, used to create derivation work or used for any reason, by means without the express, written permission of the copyright owner. If prices are stated, they are netto unit-prices and any eventual tax(es) have to be added. The company is not responsible for any printing error in technical, price and/or any other data.

Tool specifications subject to change without notice.

www.osgeurope.com

